



SUBARU

*INSTALLATION
INSTRUCTIONS*

SUBARU

OUTBACK

PART NUMBER: E551SAJ200

DESCRIPTION: OUTBACK REAR BUMPER UNDER
GUARD

KIT CONTENTS:

A.

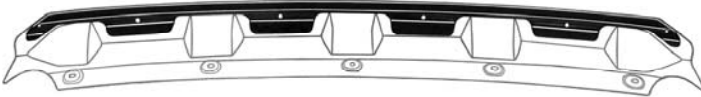

Rear Under Guard x 1

B.

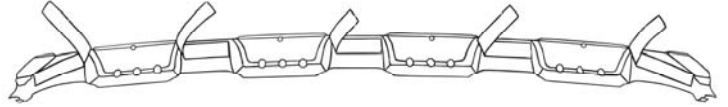

Mounting Bracket x 1

C.



Push Retainer
x 5

D.



Rivet x 7

E.



Mylar Mask x 1

F.



Alignment Tool x 1

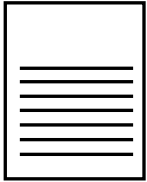

Installation
Instructions x 1

TOOLS REQUIRED:



Masking Tape

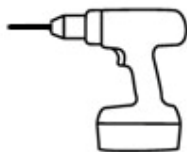

Drill with 5/16" Bit



Drill with 3/16" Bit



Pop Rivet Gun

PART NUMBER:
E551SAJ200

ISSUE:
00

DATE:
06-20-11

SUBARU OF AMERICA

PAGE
1/6

MEANING OF CHARACTERS:

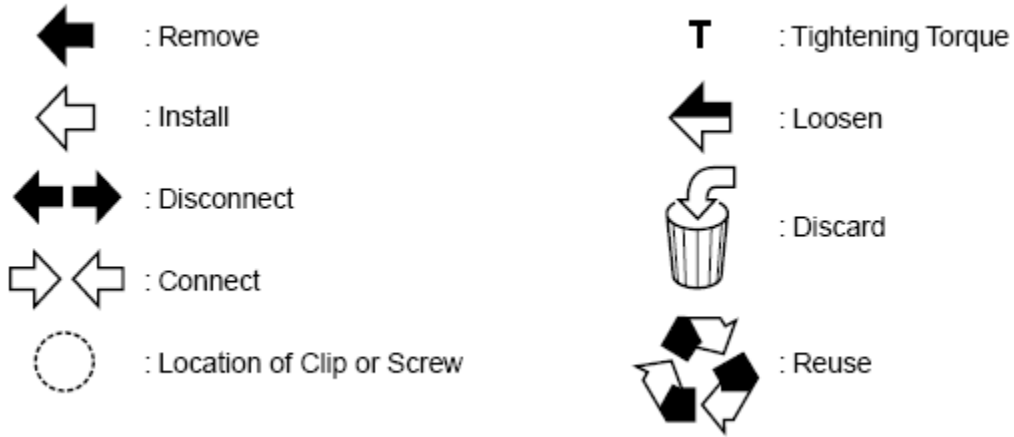

Surface Preparation

1

Make sure that all installation surfaces (shown below) are clean, free of dirt, grease, and debris. If necessary, use a clean, lint-free cloth and isopropyl alcohol based cleaner. Inspect vehicle for damage before installation of rear bumper under guard. Before beginning, vehicle and under guard must be at room temperature. If the temperature is below 60 F (15.5 C) or above 110 F (43 C), let vehicle sit indoors until the bumper and under guard are room temperature.

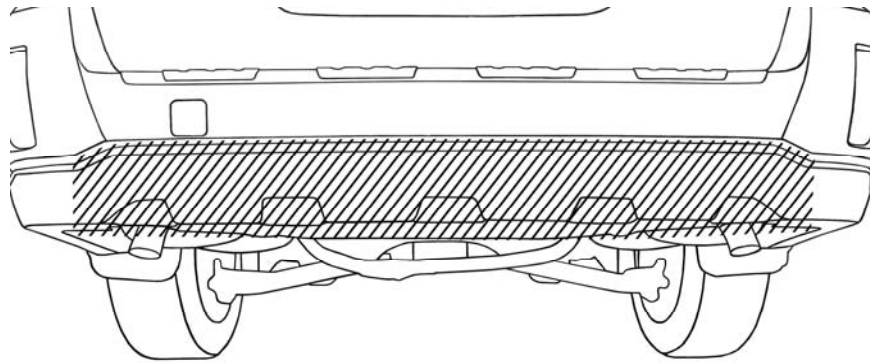

Rear Mounting Bracket Installation

2

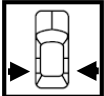

Pull tape liners back halfway. Fold tape liners upward. *NOTE: They need to be accessible in Step 8.*

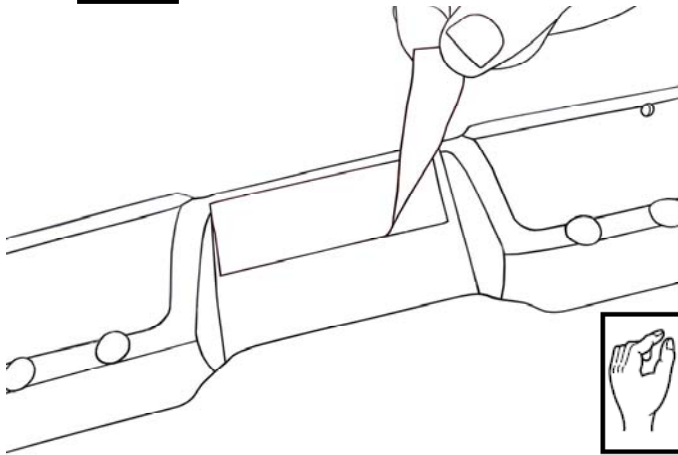

3

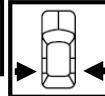

Once all tape liners are pulled back halfway, locate the index tabs on each end.

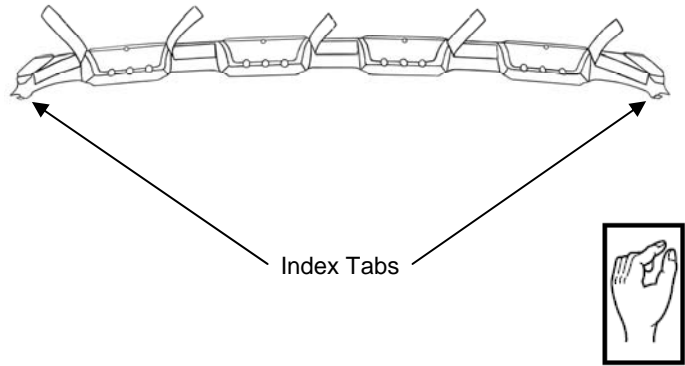

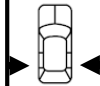
4  Hook index tabs into exhaust opening and move it side to side until you can feel the mounting bracket is centered. Pull mounting bracket upward until it touches the bumper. Apply slight pressure to the two outer tape points. *NOTE: This is only to keep mounting bracket in place until Step 5.*

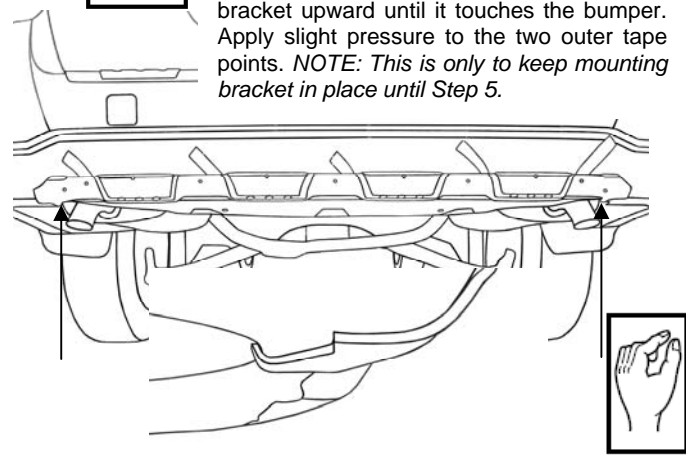

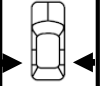

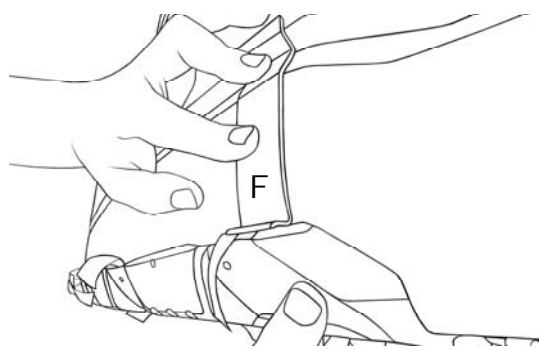
5  Starting on the right side, firmly press alignment tool into style line of bumper above the right pocket of mounting bracket. Pull mounting bracket away from bumper and adjust up or down until the top edge butts against the alignment tool. Apply pressure to corresponding tape pad.

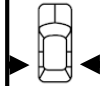

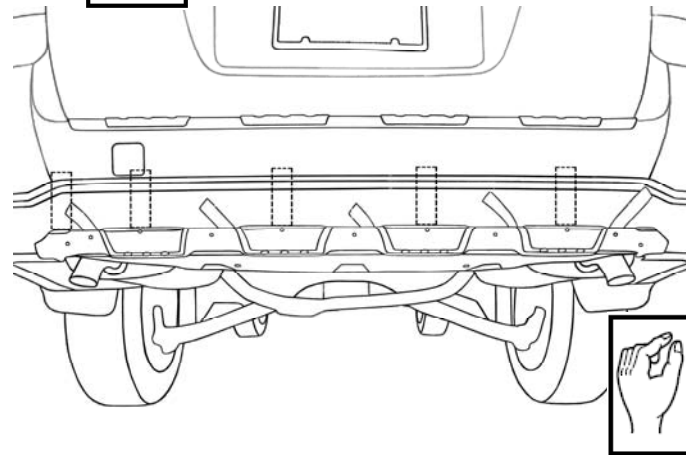
6  Working from right to left, repeat Step 5 for the remaining 5 pocket locations.

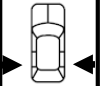

7  Use alignment tool as a check gauge to double check mounting bracket position. There should be no gap between alignment tool and mounting bracket.



8  Hold mounting bracket in place and remove all tape liners. Apply firm pressure to each tape point.

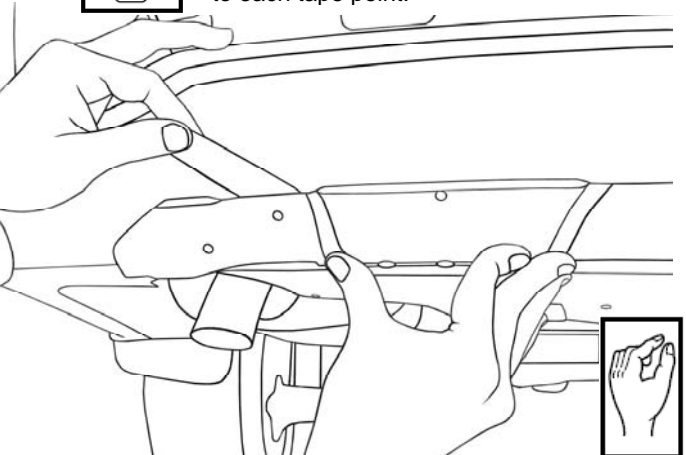

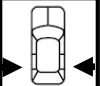
9  Center mylar mask on the bumper's lower rear surface aligning top edge with horizontal style line. Use masking tape to attach. Mylar mask protects bumper surface from scratches during installation.

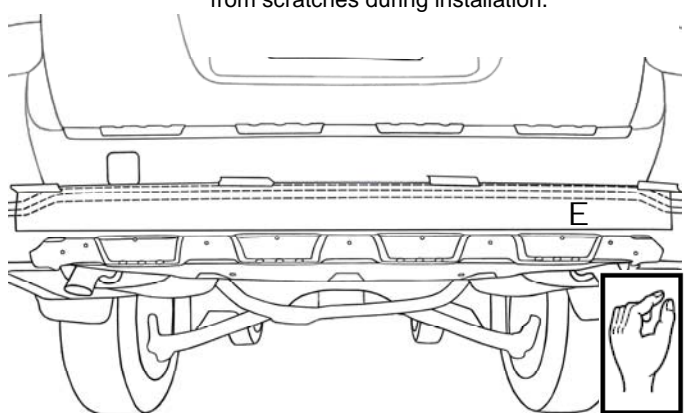

10



Reference these specified 7 locations for Steps 11 & 12.

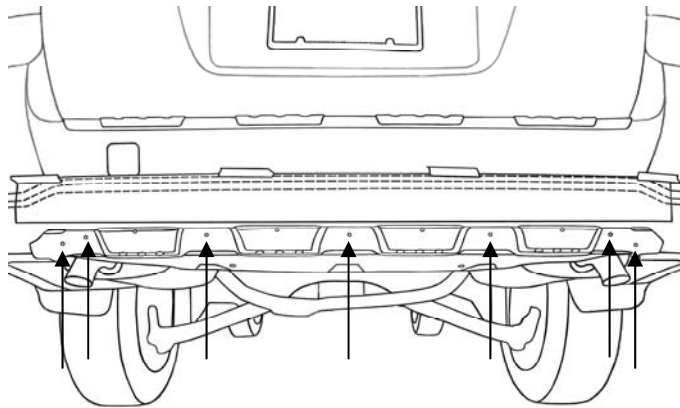

11

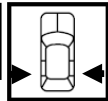

Using holes *only* on depressed surface of mounting bracket as a guide, drill through part and into bumper of vehicle with 3/16" drill bit. 7 Locations. *Do not drill* the four holes on convex surfaces of part.

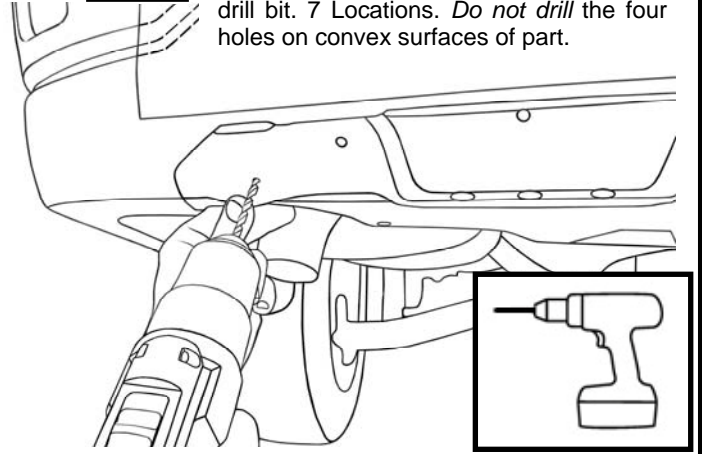

12



Use pop rivet gun at seven locations drilled in previous step.

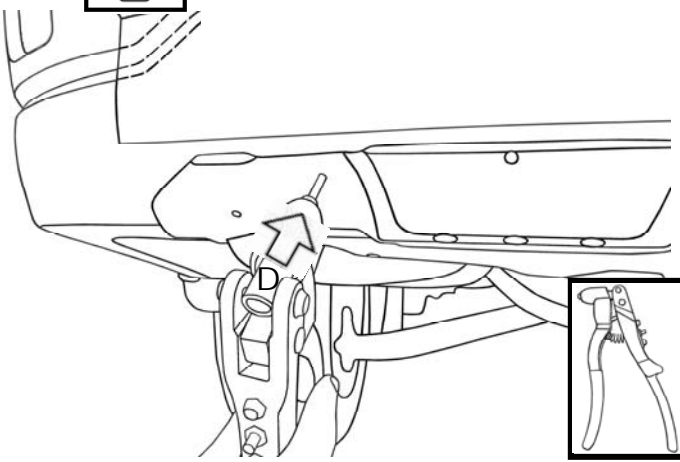

Rear Bumper Under Guard Installation

